

ECOBLOCK

- PLASTIC POLE BRACING BLOCKS

The old saying 'If it ain't broke don't fix it' obviously doesn't apply. Concrete Pole Blocks have always broken and every useless block carries a cost. Maybe everyone just took the heavy, unstable, fragile blocks for granted. Don't ask why it took so long. TransNet took a look at the issue and came up with a blindingly simple idea for a replacement that has all the strength, better performance and at a fraction of the weight of concrete.

Your average existing Heel Block weighs around 34kg. You don't want to drop one on your foot. TransNet's version weighs 5kg. The larger Breast Block weighs a mere 14kg. Think of the benefits in transport and handling as well as the ease on your back.

Under stress testing at Industrial Research Ltd. concrete crumbled fairly easily but the plastic new comer continued to resist. All EcoBlocks are certified, proven performers manufactured from recycled PE plastic & harm free to the environment throughout their long long life at which point they can be fully recycled!

Part No.	Description	Dimensions (mm)			Weight (kg)	Strength (kN)
		Length	Width	Depth		
HB450	Heel Block	450mm	350mm	100mm	5kg	135kN
HBDNUT430	Single Pole Donut Block - Humes Pole	430mm Diameter		225mm	10kg	200kN
HBDNUT480	Single Pole Donut Block - Busck Pole	480mm Diameter		225mm	14kg	200kN
BB600	Breast Block	600mm	350mm	100mm	6kg	140kN
BB900	Breast Block	900mm	350mm	100mm	11kg	150kN
BB1200	Breast Block	1200mm	350mm	100mm	14kg	200kN
AB1200	Anchor Block - 10mm Plate	1200mm	350mm	100mm	25kg	20kN*

*up to 200kN rated AB1200 is available on special request.

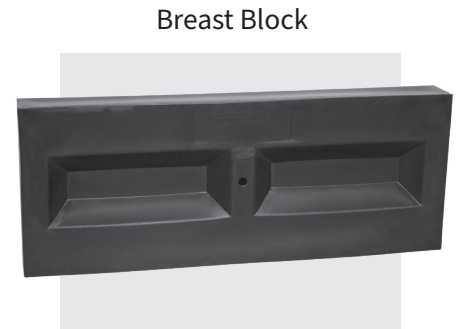

Breast Block

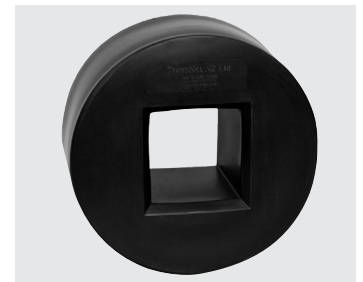

Donut Block



Heel Block



Anchor Block

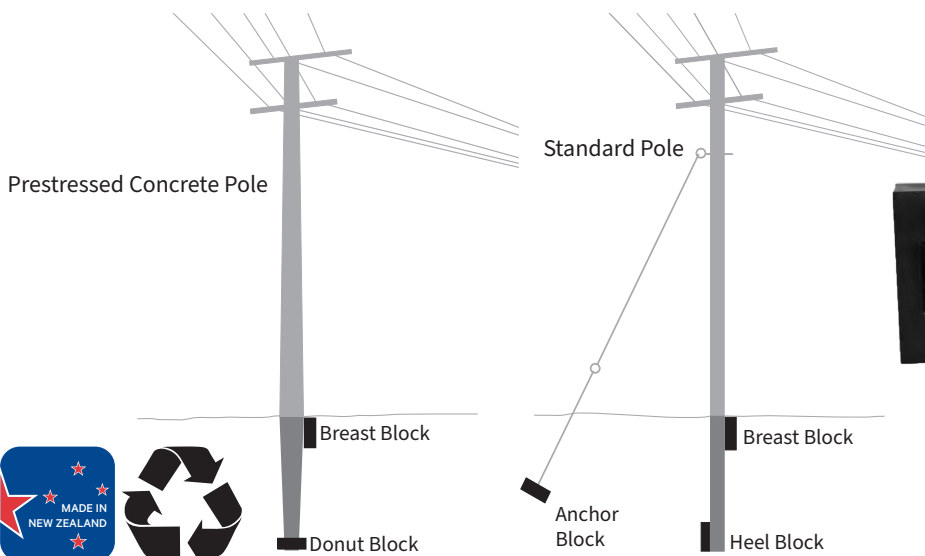

APPENDIX: TEST REPORTS

- I. **36690441/442.01** HEEL BLOCK and 900mm BREAST BLOCK
HB450
BB900
- II. **36690456.01** 600mm and 1200mm BREAST BLOCKS
BB600
BB1200
- III. **36690449.01** DONUT BLOCK
HBDNUT480
- IV. **ANCHOR BLOCK** ANCHOR BLOCK ASSESSMENT LETTER
AB1200



REPORT NUMBER: 36690441/442.01

TITLE: Mechanical testing and estimated creep
behaviour of thickened blocks

CLIENT'S NAME: TransNet NZ Ltd
Attn: Spencer Winn

CONFIDENTIAL TO: Client

DATE ISSUED: 28 November 2008

PREPARED BY: Biswajit Banerjee

PEER REVIEWED BY: Clive Stirling

Written permission is required if this report is to be reproduced for promotional purposes or in part. The name of Industrial Research Limited may not be used in advertising without consent. Any samples received by Industrial Research Limited in connection with this investigation that are not reclaimed by the client within 8 weeks of the date of issue of this report will be disposed of.

CONTENTS

1	Introduction	3
2	Related documents	3
3	Mechanical Testing of Thickened Blocks	3
	3.1 Approach	3
	3.2 Results.....	3
4	Assessment of long-term creep behaviour.....	7
	4.1 Approach	7
	4.2 Results.....	8
5	Conclusions	10

1 Introduction

TransNet NZ Ltd (TransNet) is in the process of evaluating a new CoteneTM-based plastic breast and heel block system for supporting electric utility poles. The plastic block system is intended to replace a concrete block system currently in use. TransNet is also interested in assessing the long term (20 year) creep behavior of the blocks under operating conditions.

Industrial Research Limited (IRL) had performed an assessment of the pole-block system (Report # 36690421.01, 36690425.01) and found that the blocks would have to be stiffened to meet their intended purpose. IRL suggested that increasing the wall thickness of the blocks would lead to a stiffening effect. Following that recommendation, TransNet has increased the nominal block wall thickness from 1 cm to 1.5 cm. IRL has recommended that the thickened blocks be tested mechanically before a comparative table of the properties of plastic versus concrete blocks is prepared.

This report presents the results of mechanical tests on the thickened heel and breast blocks, along with a table comparing the plastic blocks to their incumbent concrete counterparts. An assessment of the expected long term creep behavior of the blocks is also provided on the basis of numerical simulations and CoteneTM creep data provided by ICO CourtenayTM.

2 Related documents

The following documents should be referred to in conjunction with this report:

- IRL Report number 36690421.01, “*Mechanical testing of breast and heel blocks*”.
- IRL Report number 36690425.01, “*Simulation of breast and heel blocks*”.

3 Mechanical Testing of Thickened Blocks

3.1 Approach

Mechanical testing of the thickened blocks was performed using a setup similar to that described in Report # 36690421.01. Testing was carried out in a Tinius-Olsen universal testing machine with a calibrated load cell that could measure loads up to 250 kN. Displacements were measured using displacement transducers that were specially designed and calibrated for the purpose of these tests. Electrical noise originating from the testing machine necessitated that the test be started and stopped at regular load increments before a displacement measurement could be made. Hence the load-displacement curves do not show a smooth, continuous progression.

3.2 Results

The thickened heel block was loaded to 200 kN. Given that the area of application of the load for the heel block is 0.0465 m², this load corresponds to an applied normal surface traction (force per unit area) of 4.3 MPa. The breast block was loaded up to 250 kN, which is equivalent to a surface traction of 3 MPa over an area of 0.021 m².

Figure 1 shows a comparison of the load-displacement behavior of the thickened heel block and the original plastic and concrete heel blocks. The thicker heel block is stiffer than the

original plastic one. At a load of approximately 135 kN, the sides of the thickened heel block buckled and parts of the block started experiencing significant permanent deformation. Upon removal of the load, the amount of deformation in the buckled region decreased. However, a permanent bulge continued to be observed in the buckled region.

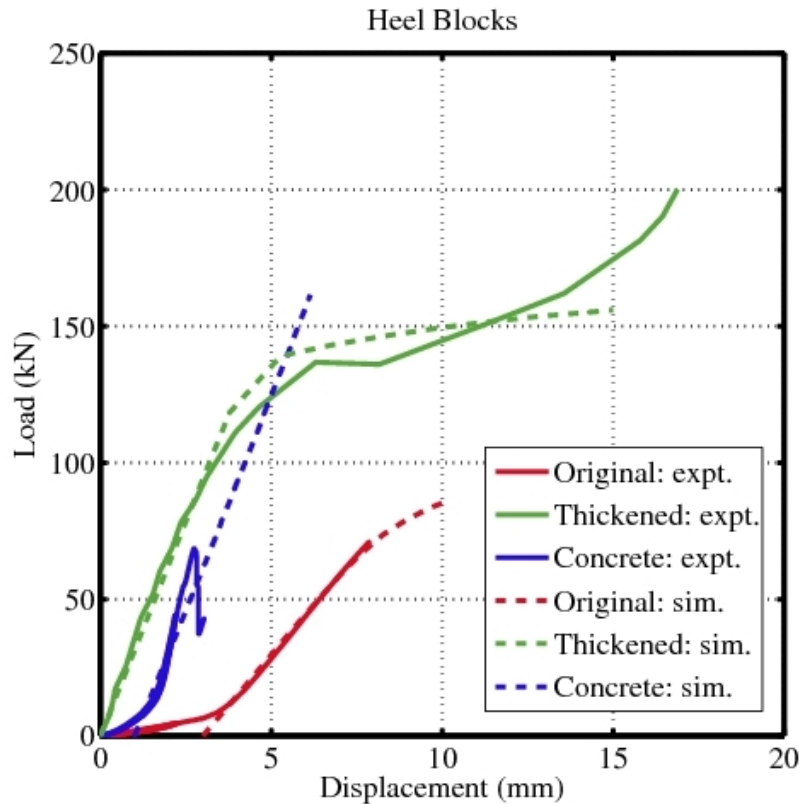

Figure 1. Load versus displacement of heel blocks

Since the area of application of the load is not the same for the concrete and plastic blocks, a comparison of the relative stiffness of the blocks is best conducted by converting the loads into normal surface tractions (force per unit area). Figure 2 displays a comparison of the surface tractions as a function of displacement for the three heel blocks. The figure shows that the thickened plastic block has approximately the same stiffness (slope of the traction-displacement curve) as the concrete block but is stiffer than the original plastic block.

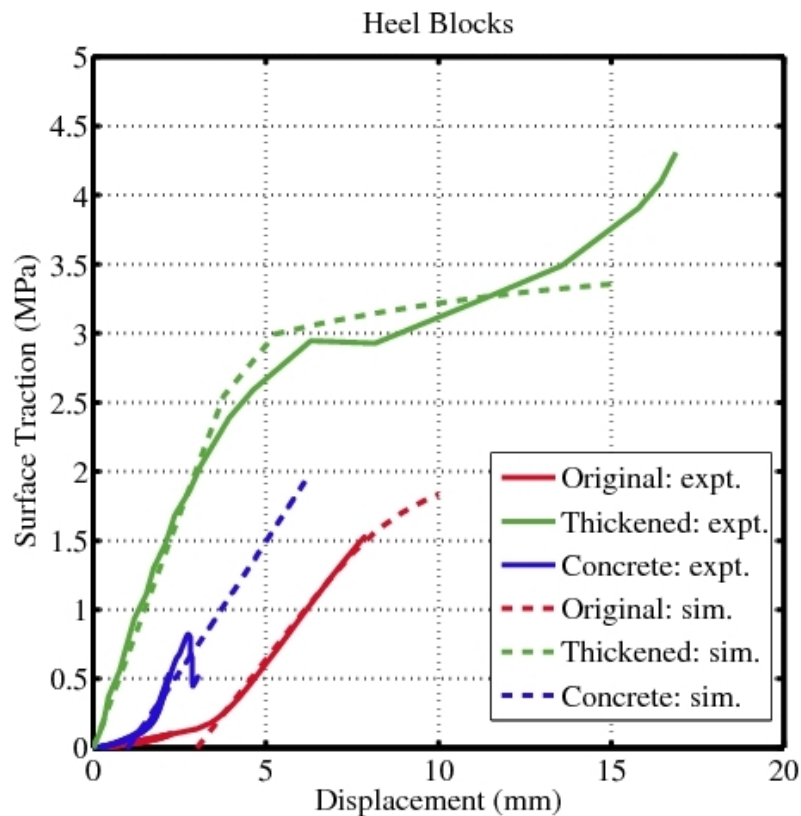

Figure 2. Surface traction versus displacement of heel blocks

The surface of the thickened breast block was more uneven than that of the thickened heel block. This is reflected in the load-displacement curve of the breast block shown in Figure 3. The block exhibits a strongly nonlinear load-displacement behaviour as the platens cannot apply the load uniformly to the surface of the block. However, the average response of the thickened block is stiffer than that of the original block.

Figure 4 shows the traction versus displacement curves for the breast blocks. As mentioned earlier, this plot provides a more direct comparison of the relative stiffnesses of the plastic blocks vis-a-vis the concrete block. The thickened plastic block is stiffer than the concrete block in the region of interest. Note that the initial apparently lower stiffness is due to the uneven loading of the breast blocks. During this stage the load is actually applied over a significantly smaller region of the block. As a result, the platen cuts into the block and there is local permanent deformation of the block where the platen and the block come into contact.

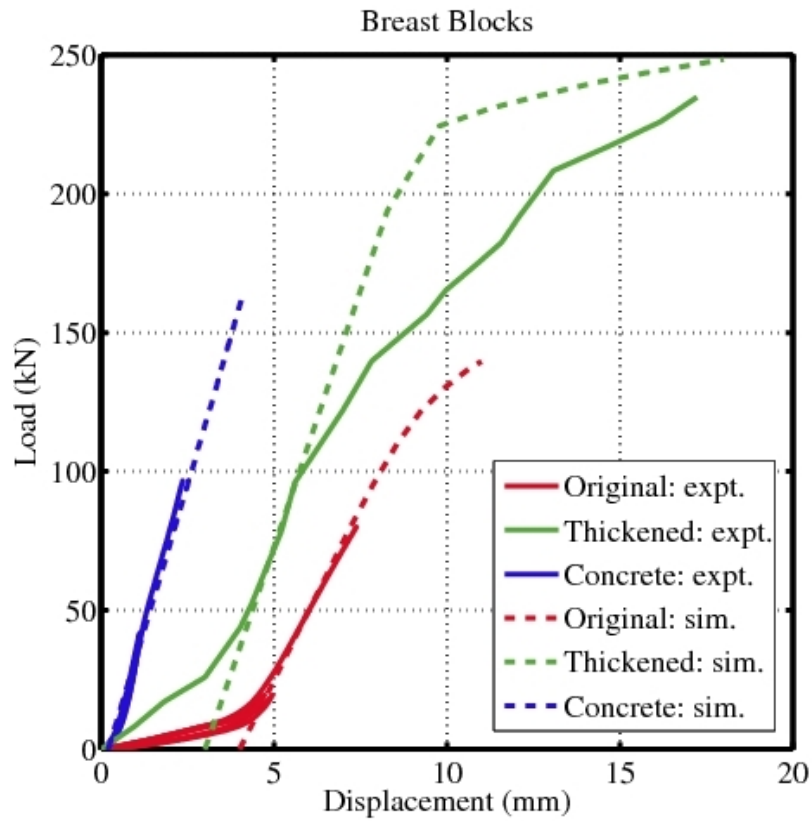

Figure 3. Load versus displacement of the breast blocks

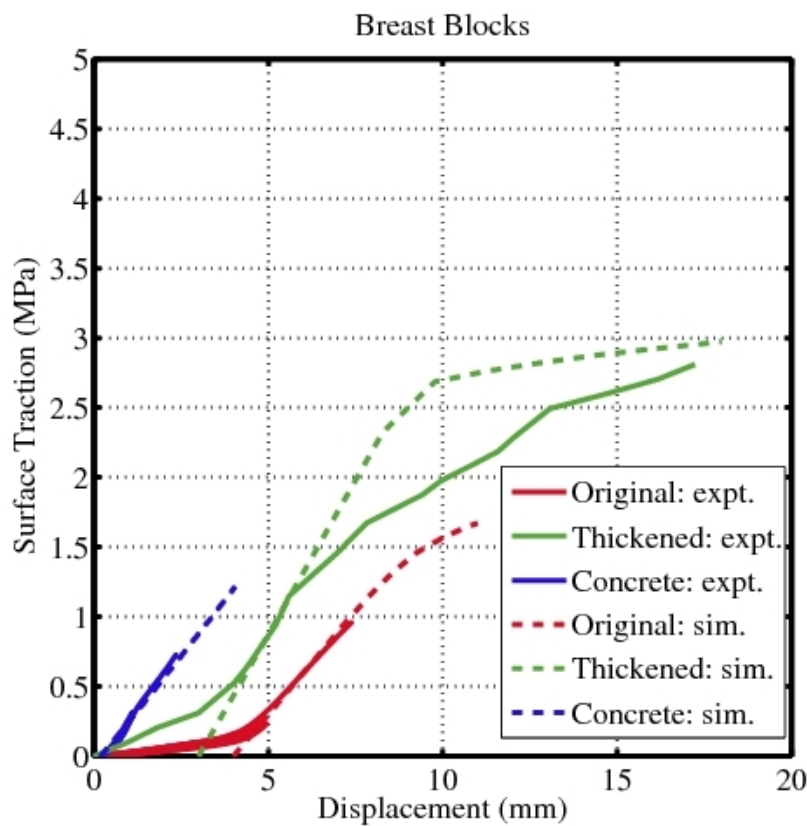

Figure 4. Surface traction versus displacement of breast blocks

A summary of the mechanical properties deduced from the mechanical testing of the blocks and their numerical simulation is given in Table 1.

Table 1. Properties of heel and breast blocks

Property	Heel Block		Breast Block	
	Plastic	Concrete	Plastic	Concrete
Exterior dimensions (cm)	44.4x34.5x9.5	45.2x33.3x10	88.5x34.5x9.5	89.7x33x9.7
Wall thickness (cm)	1.5	-	1.5	-
Weight (kg)	5	34	12	68
Elastic modulus (MPa)	200-300	30-40	200-300	30-40
Stress at initial yield (MPa)	1.40-1.55	-	1.40-1.55	-
Stiffness (MPa/mm)	0.68	0.65	0.33-0.38	0.33
Load at yield/failure (kN)	135-140	68	150-200	-
Traction at yield/Failure (MPa)	3	0.8	1.8-2.5	-
Displacement at yield/failure (mm)	6	1.5	5-10	-

4 Assessment of long-term creep behaviour

4.1 Approach

On the basis of tensile tests at 20°C under stresses up to 6.6 MPa and for times up to approximately 200 days, the manufacturer has estimated that the long term creep behaviour of rotationally molded parts (made from neat CoteneTM) will follow the relation

$$\epsilon(t) = 0.015\sigma^{1.9}\ln(t) + 0.075\sigma^{1.9} \quad (1)$$

where the strain (ϵ) is in %, the tensile stress (σ) is in MPa, and the time (t) is in hours. The experimental data provided by the manufacturer suggests that this relation may be extrapolated to times of the order of 10 to 20 years.

Since the plastic blocks contain carbon black, the creep behaviour of the material forming the blocks will be different from that of the neat polymer. In general, the creep resistance of the blocks will be higher than that of the neat polymer. However, the base polymer will degrade over time periods of the order of tens of years and the creep resistance will also degrade accordingly.

To assess the long term creep behaviour of the blocks, the expected principal stresses in the thickened blocks have been computed from numerical simulations, the creep strains have been calculated at these levels of stress using equation (1), and the corresponding

displacements in the blocks have been calculated. Estimates have then been made on whether these displacements are acceptable. Since the stresses of interest are compressive, it has been assumed that the creep equation remains unchanged under tension or compression. It has also been assumed that, under normal conditions, the blocks are maintained at the stress state that results from a deformation of approximately 1 mm of the load-bearing surface.

4.2 Results

Figure 5 shows the third principal stress in the thickened heel block at a surface displacement of approximately 1 mm. Much of the block is at a stress state between 1 MPa tension and 1 MPa compression. However, the region near the top of the block is in a state of higher compressive stress; approximately 2 MPa to 3 MPa. For the breast block shown in Figure 6, the corresponding stresses are in the range of 1 MPa to 2 MPa.

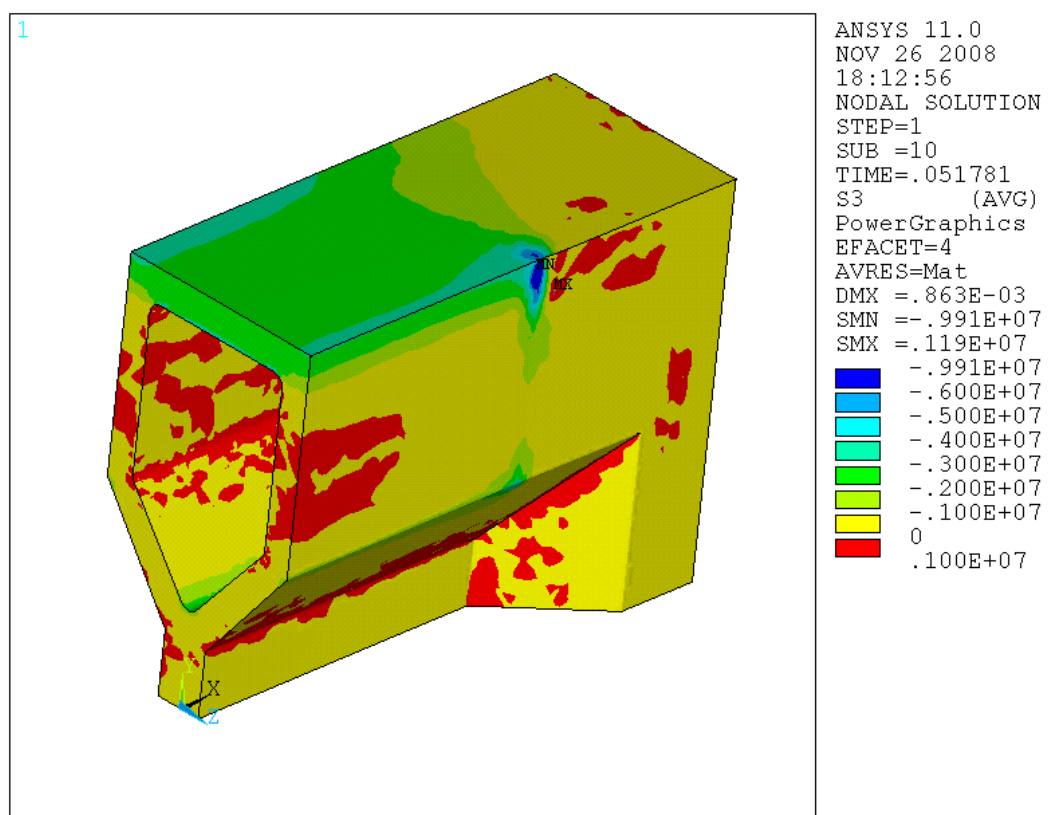

Figure 5. Third principal stress in the thickened heel block. Units are Pa.

If we look at the strain versus time curves between stress levels of 1 MPa to 3 MPa, as given in Figure 7, we notice that the peak strains are in the range of 2% over 20 years. The corresponding displacements are approximately 2 mm. Such small displacements will not affect the performance of the blocks over the 20 year period of interest.

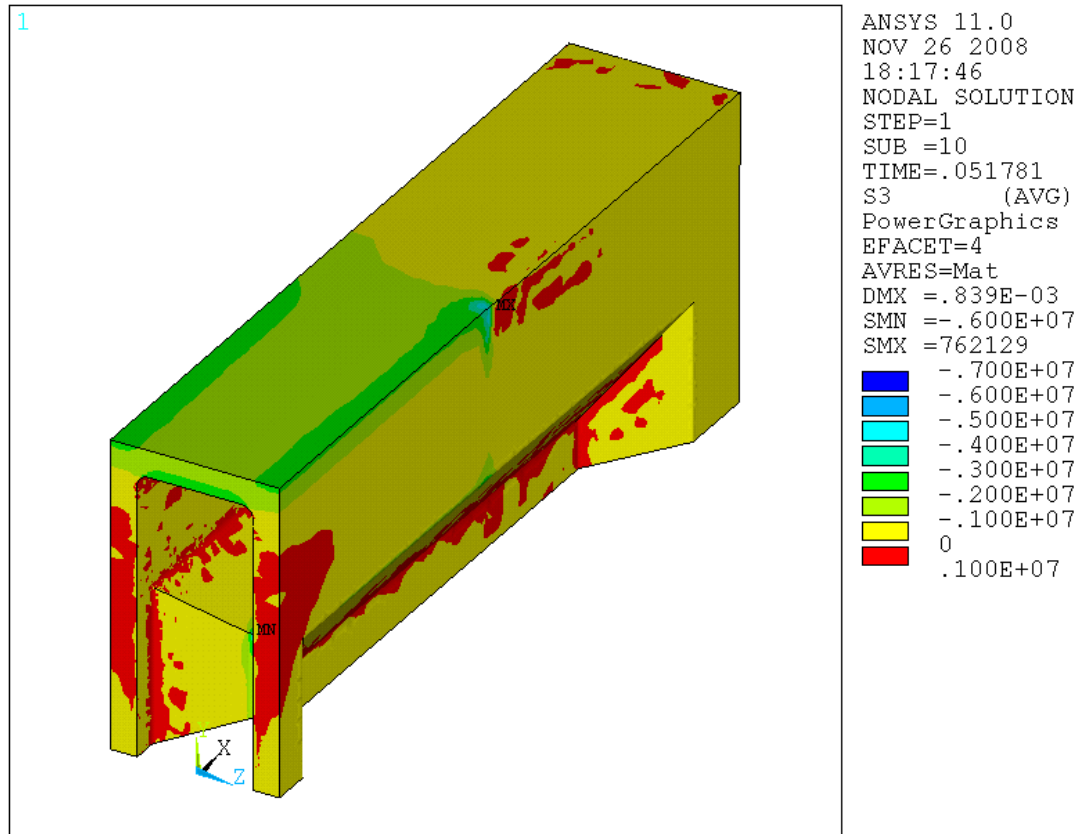

Figure 6. Third principal stress in the thickened breast block

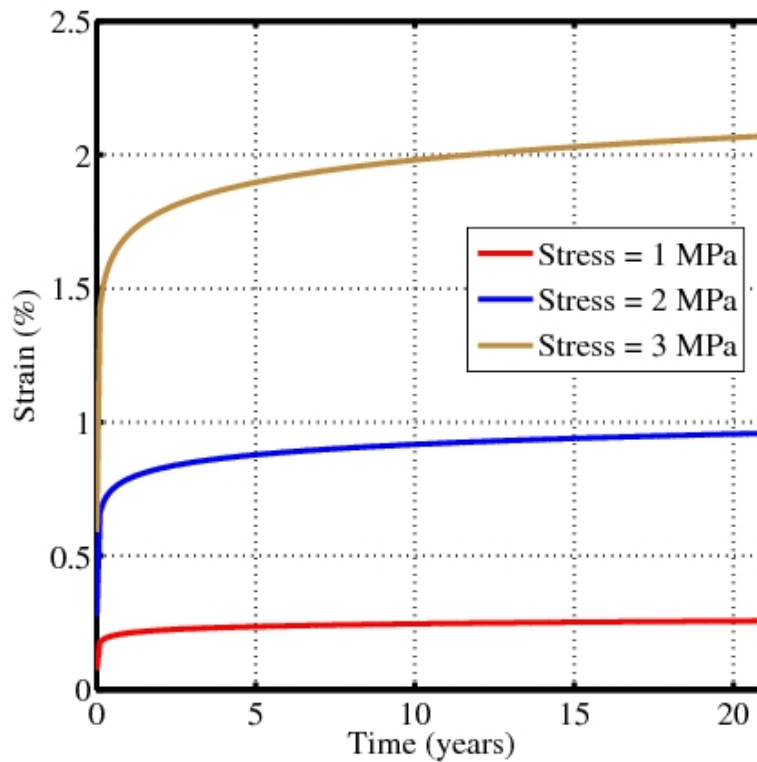

Figure 7. Creep strain as a function of time

5 Conclusions

The mechanical tests show that the thickened plastic blocks perform as well as or better than the concrete blocks provided that their surfaces are reasonably flat.

Examination of the creep data provided by the material manufacturer suggests that creep is not an issue over the life of the blocks provided that they are not excessively loaded during normal operating conditions.



REPORT NUMBER: **36690456.01**

TITLE: **Compression tests on TransNet plastic blocks BB 600 and BB 1200**

CLIENT NAME: **TransNet New Zealand Ltd.**

Attn: Spencer Winn

CONFIDENTIAL TO: **Client**

DATE ISSUED: **20 May, 2009**

PREPARED BY: **Biswajit Banerjee**

CHECKED AND APPROVED BY: **Clive Stirling**

Written permission is required if this report is to be reproduced for promotional purposes or in part. The name of Industrial Research Limited may not be used in advertising without consent. Any samples received by Industrial Research Limited in connection with this investigation that are not reclaimed by the client within 8 weeks of date of issue of this report will be disposed of.

Contents

1	Introduction	3
2	Related Documents	3
3	IRL Deliverables	3
4	Approach	3
5	Results	6
6	Discussion and Conclusions	6

1 Introduction

TransNet New Zealand (TransNet) has introduced new Cotene™-based plastic breast and heel blocks into the New Zealand market. Mechanical tests performed by Industrial Research Limited (IRL) have shown that the blocks perform adequately under high loads (see IRL Reports # 36690421.01 and # 36690441/442.01 for details).

This report presents the results from identical mechanical tests performed on two new blocks designed by TransNet, named BB600 and BB1200.

2 Related Documents

The following documents should be consulted in conjunction with this report:

- IRL Report # 36690421.01: *Mechanical testing of heel and breast blocks.*
- IRL Report # 36690441/442.01: *Mechanical testing and estimated creep behaviour of thickened blocks.*

3 IRL Deliverables

As per the Work Order Agreement the IRL deliverable is a report on the results of experimental tests on the BB 600 and BB 1200 plastic blocks.

4 Approach

The approach taken in the mechanical testing performed for this study was similar to that described in IRL Reports # 36690421.01 and # 36690441/442.01. The dimensions of the blocks, the loading plate dimensions, and the loaded area of the blocks are given in Table 1.

Table 1 – Dimensions and loaded area of blocks.

Block type	Exterior dimensions (cm)	Loading plate dimensions (cm)	Actual loaded area (cm²)
BB 600	48.8×34×9.5	24.2×34.3	524
BB 1200	118×34.3×9.5	43×34.3	1005

Photographs of the blocks after testing are shown in Figure 1. Photographs of the experimental setup are shown in Figure 2.

The compression tests were performed on an Instron 1345 universal testing machine calibrated to traceable national standards. Compressive load and crosshead displacement were recorded during each test. The load was applied via top plates identical to those used for previous tests. The test was deemed complete when the edges of the top plates were observed to be cutting into the plastic.

To determine the effective stiffness of the blocks, the load-displacement data obtained from the test were converted into a traction-nominal strain form and straight lines were fitted to the curves in the regions where the response was observed to be linear.



(a) Block BB 600.



(b) Block BB 1200.

Figure 1 – *Photographs of the blocks that have been tested.*



(a) BB 600 (close up).



(b) BB 600.

Figure 2 – *Experimental setup for the testing the blocks. BB 600 shown in the testing machine.*

5 Results

The load-displacement curves shown in Figure 3(a) indicate that specimen BB 600 can be loaded up to 140 kN before the deformation becomes nonlinear. This load corresponds to a displacement of around 12 mm. Specimen BB 1200 does not show any significant nonlinearity up to the final load of approximately 200 kN. The initial low stiffness portion of the curve is due to the uneven surface of the blocks.

The corresponding traction-displacement curves are shown in Figure 3(b). The traction is calculated by dividing the load by the loading area. It is assumed that the loading area remains constant through the test. This assumption is reasonable in the linear regime of the test which is of primary interest. The traction-displacement curves show that both blocks have similar stiffnesses.

The traction-displacement curve suggests that estimates of the stiffness of blocks of intermediate sizes may be made without significant additional testing. Figure 4 shows a plot of the traction as a function of the nominal strain. The nominal strain has been computed by dividing the displacement by the initial thickness of the block and expressing the result as a percentage. The straight line fits to the two curves show that the effective stiffness of BB 600 is 32.5 MPa while that of BB 1200 is 34.4 MPa. The peak allowable traction for BB 600 is around 2.4 MPa, while that for BB 1200 is greater than 2 MPa (and probably close to 2.4 MPa).

To estimate the slope of the load-displacement curve and the maximum allowable load of blocks of sizes other than those tested, one can take the lower values of the effective stiffness and peak allowable traction and multiply those with the loaded area. The nominal strain can similarly be converted into displacement by multiplying with the thickness of the block. However, care must be exercised while extrapolating from test data and the accuracy of such estimates should be verified.

A summary of the mechanical properties deduced from the tests is given in Table 2.

Table 2 – *Mechanical properties of blocks BB 600 and BB 1200.*

Property	BB 600	BB 1200
Exterior dimensions (cm)	48.8×34×9.5	118×34.3×9.5
Weight (kg)	6	14
Load at yield (kN)	140	> 200
Displacement at yield (mm)	12.5	> 10
Traction at yield (MPa)	2.6	> 2
Effective stiffness (MPa)	32.5	34.4

6 Discussion and Conclusions

The tests performed on the plastic blocks BB 600 and BB 1200 show that both blocks have effective stiffnesses of approximately 33 MPa. The actual load-displacement behaviour of the blocks will depend on the area of the block surface on which the load is actually applied. These loads and displacements should be calculated for each loading case and compared with the peak allowable loads (load at yield) determined from the experiments.

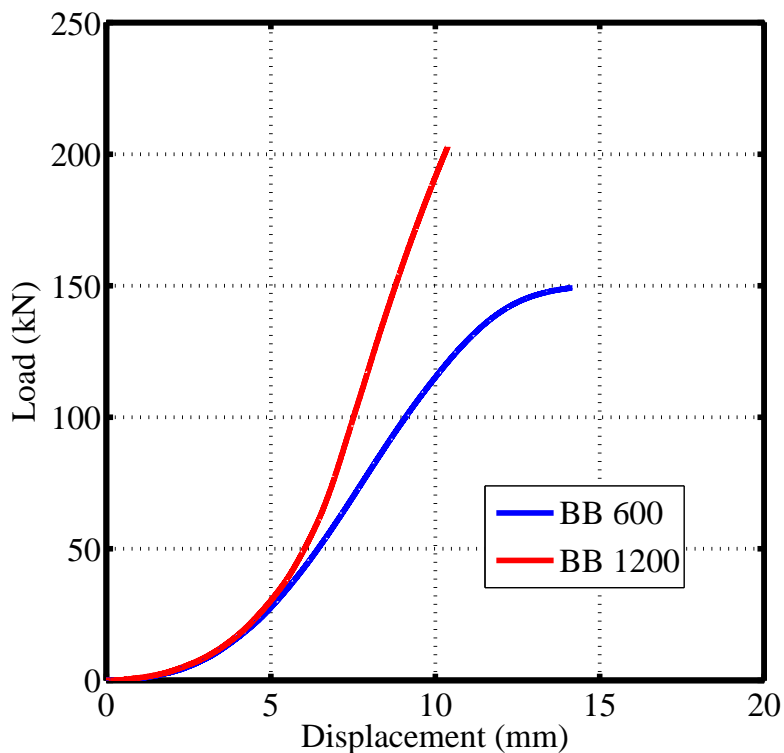

(a) Load vs. displacement.

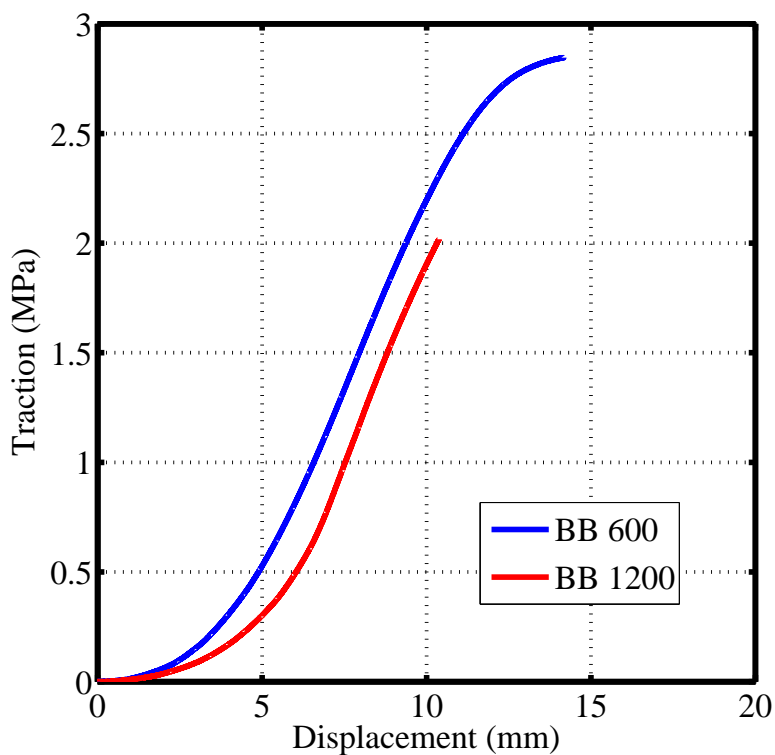

(b) Traction vs. displacement.

Figure 3 – Load-displacement plots for BB 600 and BB 1200.

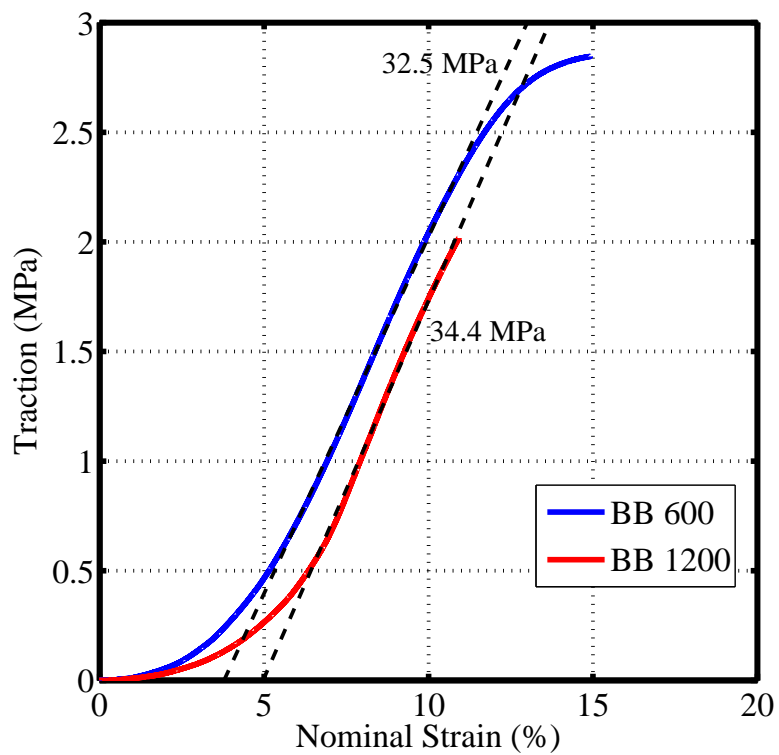

Figure 4 – Traction vs. strain data showing effective elastic moduli of BB 600 and BB 1200.



REPORT NUMBER: 36690449.01

TITLE: Evaluation of Plastic 'Donut'
Support Blocks for Power Poles

CLIENT NAME: TransNet New Zealand Ltd

Attn: Spencer Winn

CONFIDENTIAL TO: Client

DATE ISSUED: 16 June, 2009

PREPARED BY: Biswajit Banerjee

CHECKED AND APPROVED BY: Clive Stirling

Written permission is required if this report is to be reproduced for promotional purposes or in part. The name of Industrial Research Limited may not be used in advertising without consent. Any samples received by Industrial Research Limited in connection with this investigation that are not reclaimed by the client within 8 weeks of date of issue of this report will be disposed of.

Contents

1	Introduction	3
2	Related Documents	3
3	IRL Deliverables	3
4	Approach	4
4.1	Estimating the loads	4
4.2	Testing of Donut-1	4
4.2.1	Hole integrity test	4
4.2.2	Side load/bearing test	5
4.2.3	Top-load/compression test	5
4.3	Testing of Donut-2	5
4.3.1	Slot integrity test	5
4.3.2	Slot side load/bearing test	7
5	Results	8
5.1	Estimated loads	8
5.2	Donut-1	8
5.2.1	Hole integrity test	8
5.2.2	Side load/bearing test	11
5.2.3	Top-load/compression test	11
5.3	Donut-2	12
5.3.1	Slot integrity test	12
5.3.2	Slot side load/bearing test	15
5.4	Summary	17
6	Conclusions and Recommendations	17
	Appendix A Photographs of testing rig and samples	18

1 Introduction

TransNet New Zealand (TransNet) has developed and manufactured prototypes of new donut shaped, CoteneTM-based plastic blocks for supporting concrete poles. Previous mechanical tests performed by Industrial Research Limited (IRL) on blocks of a rectangular geometry have shown that the blocks perform adequately under high loads (see IRL Reports # 36690421.01 and # 36690441/442.01 for details). Since the load distributions on these two 'Donut' block designs differ from that on the rectangular blocks, and from each other, five new tests have been performed to quantify the load carrying capacity of the donut blocks.

This report presents the results of the five mechanical tests performed on the two new 'donut' block designs, designated 'Donut-1' and 'Donut-2' in IRL Proposal # 36690449.01. Donut-1 is a round, rotationally moulded block, with a square hole in the centre. The hole is tapered to conform to the dimensions of the concrete electric utility poles which the block will support. Donut-2 is also rounded and rotationally moulded. However, this block is intended to act as a support at the bottom of one or more electric poles and has a slot along the diameter.

The five tests conducted on the blocks were:

- Donut-1:
 1. Hole integrity test.
 2. Side-load/bearing test.
 3. Top-load compression test.
- Donut-2:
 1. Slot integrity test.
 2. Side-load/bearing test.

Brief descriptions of the tests are given in Section 4. In Section 5 the results from these tests are compared with estimated in-service loads on the blocks obtained from analytical calculations and finite element simulations. Conclusions and recommendations are given in Section 6.

2 Related Documents

The following documents should be consulted in conjunction with this report:

- IRL Proposal # 36690449.01: *Developmental evaluation of plastic 'Donut' power pole support blocks* of 20 February, 2009.
- IRL Report # 36690421.01: *Mechanical testing of heel and breast blocks* of 17 October, 2008.
- IRL Report # 36690441/442.01: *Mechanical testing and estimated creep behaviour of thickened blocks* of 28 November, 2008.

3 IRL Deliverables

As per IRL Proposal # 36690449.01, the IRL deliverable is a report covering the loads sustained by the donuts, their modes of failure, and any design modifications and other recommendations arising out of the analysis of the test data.

4 Approach

All physical testing was conducted at 10 mm/min on an Instron 1345 universal testing machine. The estimated loads were determined from finite element analyses of concrete poles of two sizes - 9.5 m and 12.5 m.

4.1 Estimating the loads

The vertical loads on Donut-2 due to the weight of the concrete poles were calculated by assuming that each pole type contained 3.5% by volume of steel rebar of density 7850 kg/m³. Each pole was assumed to have 4 rebars. The concrete was assumed to have a density of 2400 kg/m³. The volume of each pole was calculated from the finite element models of the poles. Table 1 shows the vertical load exerted by each concrete pole under these assumptions.

Table 1 – Vertical loads due to the poles.

Pole size	Concrete		Rebar		Total Mass (kg)	Vertical force (kN)
	Volume (m ³)	Mass (kg)	Volume (m ³)	Mass (kg)		
9.5 m	0.346	830.3	0.012	98.5	928.8	9.1
12.5 m	0.578	1386.4	0.021	154.5	1550.9	15.2

The bearing loads on the donut blocks were estimated from finite element analyses of the poles using a procedure similar to that reported in IRL Report # 36690441/442.01. However, in the calculations performed for the donut blocks, the composition of the concrete poles was modified so that a more realistic 3.5% of volume of the pole was assumed to be rebar. A displacement of 0.5 m was applied to the top of the concrete poles. The bottom of each pole was constrained in the vertical direction. To simulate the effect of the block, a region at the bottom of the pole of height equal to that of the block was constrained as shown in Figure 1. The effect of soil pressure was calculated using the relation $p = \nu \rho g h$ where $\nu = 0.3$ is the Poisson's ratio of the soil, ρ is the nominal soil density (1500 kg/m³), g is the acceleration due to gravity and h is the depth of the pole below ground level. Only half of the pole was modelled to take advantage of the symmetry of Donut-1.

4.2 Testing of Donut-1

Three experiments were performed on Donut-1. These were the bearing test, the hole integrity test, and the compression test.

4.2.1 Hole integrity test

In this test the donut was placed with one of its flat faces on a support plate. A peg (simulating the bottom end of a power pole) was pushed into the hole to determine the load required to yield and or split the donut. A schematic of the experimental set-up is shown in Figure 2. Photographs of the sample during hole integrity testing are given in Figure 13 of Appendix A.

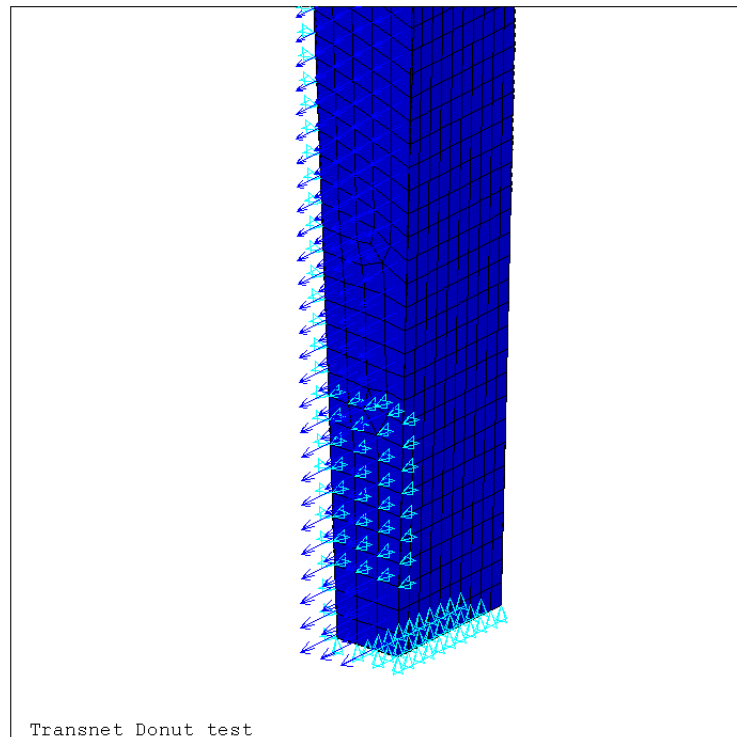

Figure 1 – Boundary conditions used to estimate the loads on the donuts.

4.2.2 Side load/bearing test

In this test the donut was turned on its side and with half of its circular face supported in a cradle. A vertical load was then applied to the donut via a bar fitted in the hole. The aim of the test was to evaluate the bearing strength of the donut, i.e. its ability to resist horizontal loads expected during use. A schematic of the experimental set-up is shown in Figure 3. Photographs of the test fixtures and the sample during the bearing test are given in Figure 14 of Appendix A.

4.2.3 Top-load/compression test

In this test the donut was placed with one of its flat faces on a support plate. A compression load was applied via a flat plate to the top face of the donut to measure its crushing strength. Photographs of the test fixtures and the sample during the compression test are given in Figure 15 of Appendix A.

4.3 Testing of Donut-2

Two experiments were performed on Donut-2. These were the bearing test and the slot integrity test.

4.3.1 Slot integrity test

In this test the donut was placed with its flat face on a support plate and an indenter in the shape of the bottom end of two power poles was pushed into the tapered slot on the donut. The aim of this test was to determine what vertical load the donut would support before crushing of the bottom and sides of slot occurred or the donut split. A schematic of the experimental set-up is shown in Figure 4. Photographs of the sample and the test fixtures during slot integrity testing can be found in

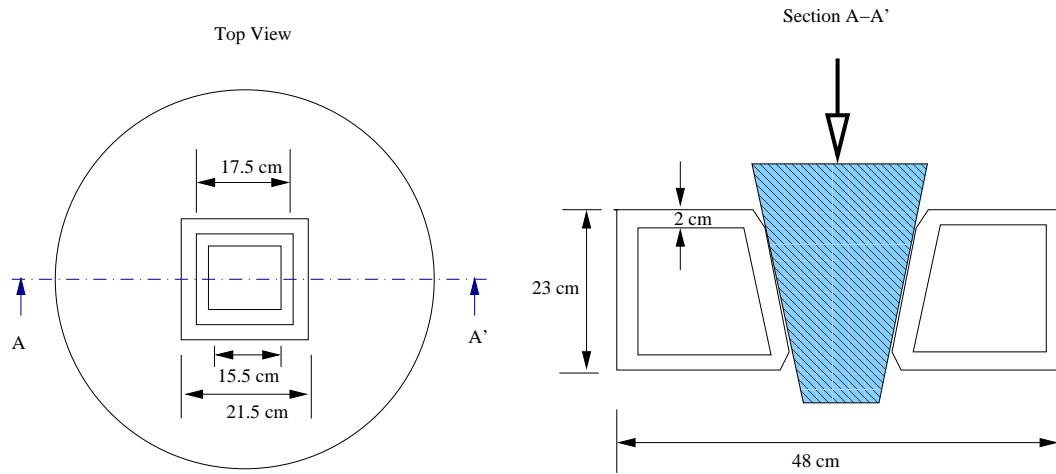

Figure 2 – Schematic of experimental set-up for Donut-1 hole integrity test.

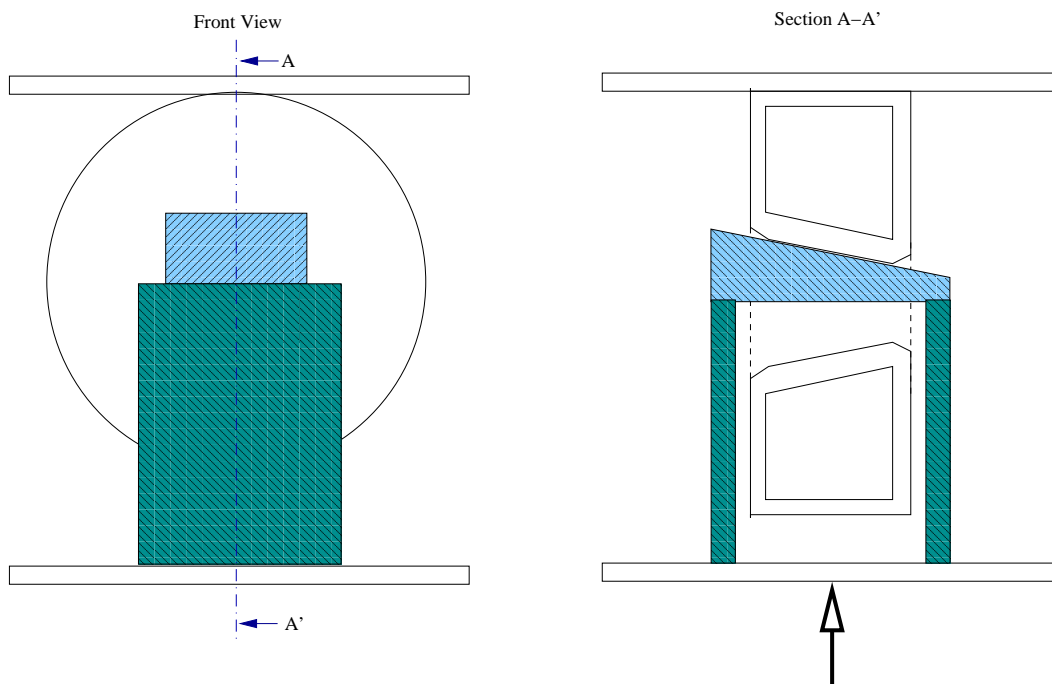

Figure 3 – Schematic of experimental set-up for Donut-1 bearing test.

Figure 16 of Appendix A.

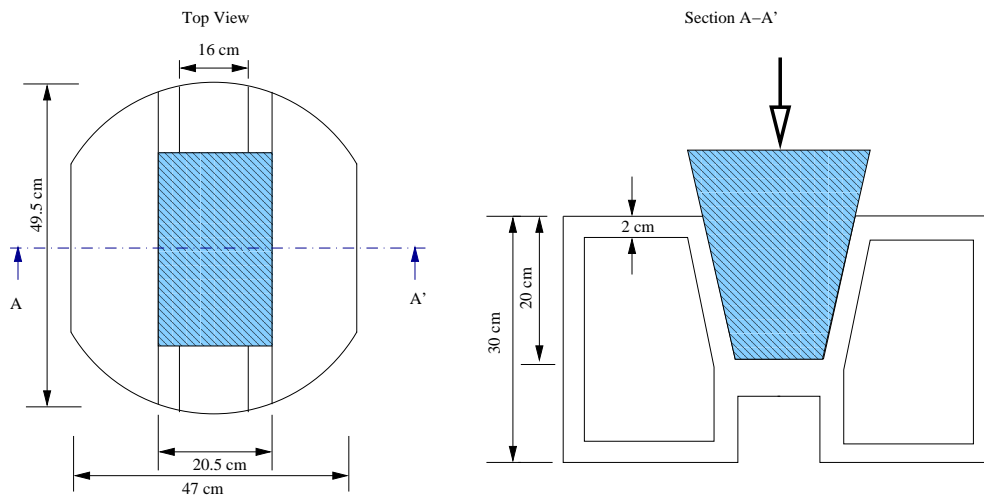

Figure 4 – Schematic of experimental set-up for Donut-2 slot integrity test.

4.3.2 Slot side load/bearing test

In this test the donut was turned on its side (so the slot was horizontal) and supported in a cradle. A vertical load was then applied to one wall of the slot via a bar (simulating the contact area of the sides of two concrete power poles) fitted in the slot. The aim of the test was to evaluate the bearing strength of the donut, i.e. its ability to resist horizontal loads expected during use. A schematic of the experimental set-up is shown in Figure 5. Photographs of the sample and the test fixtures during slot integrity testing can be found in Figure 17 of Appendix A.

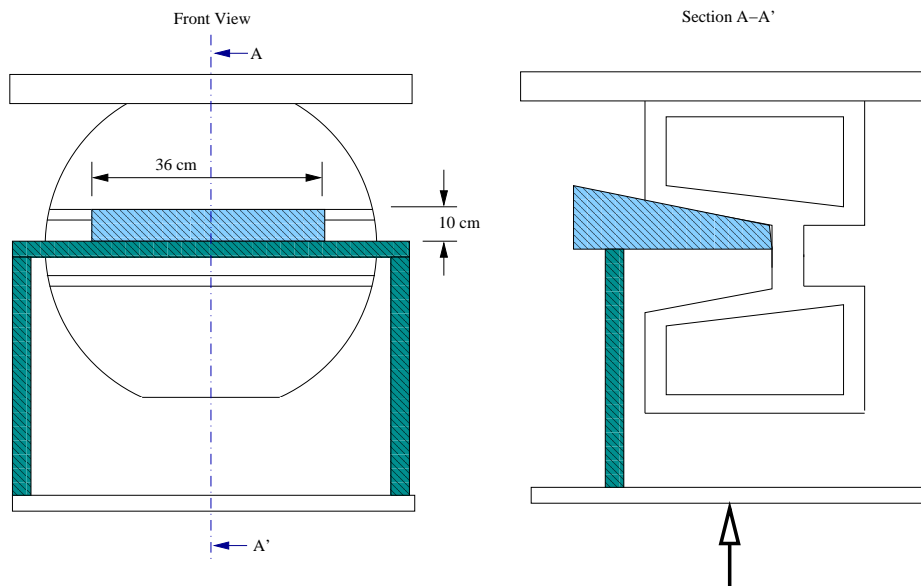

Figure 5 – Schematic of experimental set-up for Donut-2 slot bearing test.

5 Results

5.1 Estimated loads

The vertical load due to the weight of a pole affects the integrity of the hole and slot in Donut-1 and Donut-2, respectively. This is because this vertical load acts at a driver of the wedge end of the utility pole into the hole/slot. For the donut blocks to be fit for purpose, they should be able to withstand the weight of the pole without significant deformation or failure. The vertical load is also important because Donut-2 should be able to support that load when poles are placed in the slot. Table 2 lists the expected in-service vertical loads that the two donut blocks have to withstand.

Table 2 – Expected in-service vertical loads.

Donut-1 Hole Integrity Load			
9.5 m pole	9.1 kN		
12.5 m pole	15.2 kN		
Donut-2 Slot Integrity Load			
	1 pole	2 poles	3 poles
9.5 m pole	9.1 kN	18.2 kN	27.3 kN
12.5 m pole	15.2 kN	30.4 kN	45.6 kN

Figure 6 shows the boundary conditions and reactions of Donut-1 for three situations simulated for the two pole sizes. Notice that the reaction forces on the donut are negligible when a breast block is present. Two different boundary conditions have been used to simulate the bearing load on the slot in Donut-2. These boundary conditions and the corresponding reactions of the donut are shown in Figure 7.

The expected horizontal load at the base of a pole due to a horizontal deflection of 0.5 m at the load of the pole in the region constrained by the donut blocks is listed in Table 3. The corresponding expected tractions on the donut blocks have been calculated assuming a representative contact area of 0.033 m² for Donut-1 and 0.036 m² for Donut-2. In the case where there is no breast block to support the pole, the moment on the donut surface is quite high even though the sum of the forces over the area of contact is relatively small. The total compressive load on the donut has been listed in this case because that will be the maximum load that the donut has to withstand.

5.2 Donut-1

5.2.1 Hole integrity test

The maximum area of contact between the wedge and Donut-1 for the hole integrity test was 0.14 m². The wedge was an excellent fit to the hole and rested in the rectangular tapered hole with less than 1 mm variation round the hole. Total conformation to the hole took place at a load of approximately 10 kN. Donut-1 resisted the load up to approximately 50 kN at which stage the penetrator block began to slip through the hole. At 91 kN the hole stopped resisting the applied force and the wedge went through unopposed. The test was deemed over at that point.

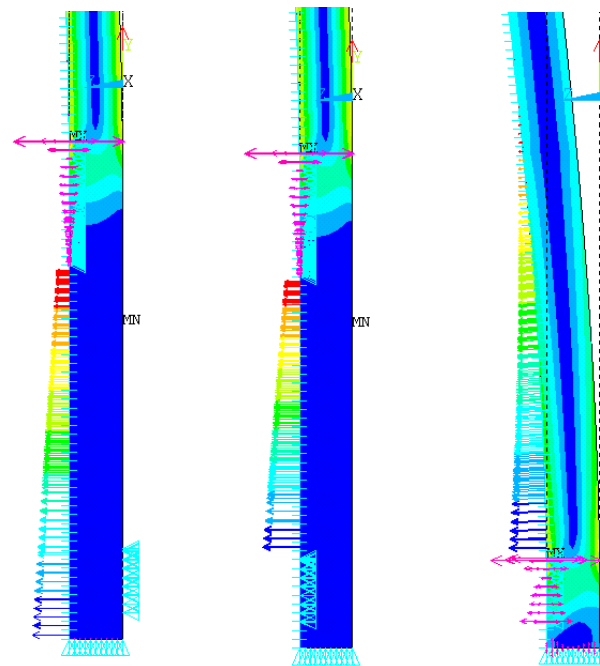

(a) 9.5 m pole.

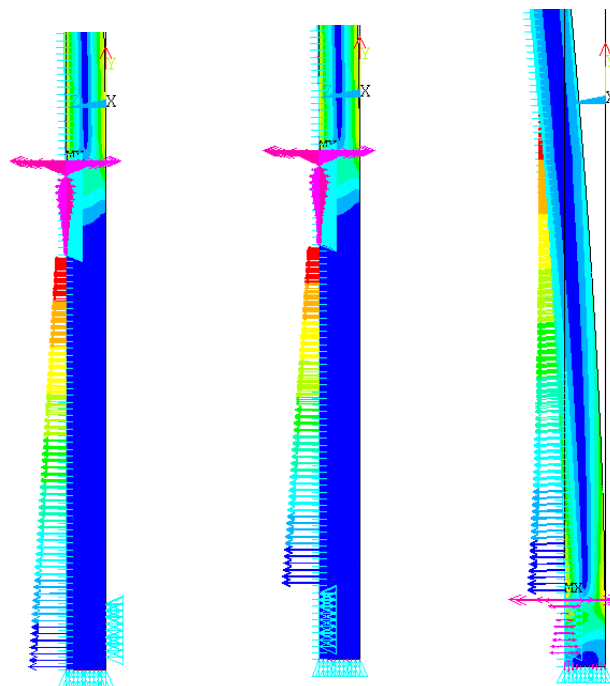

(b) 12.5 m pole.

Figure 6 – Boundary conditions and reactions corresponding to Donut-1 for the two pole sizes. The displacement boundary conditions representing the donut (and the breast block where present) are shown in light blue, the soil pressure is shown in coloured arrows, and the reactions are shown in magenta.

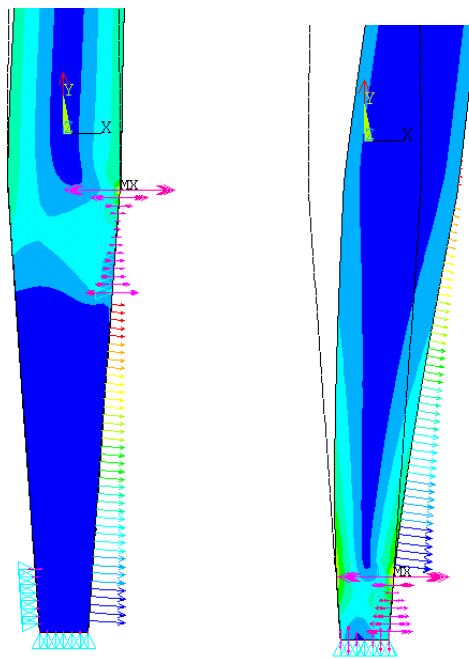

(a) 9.5 m pole.

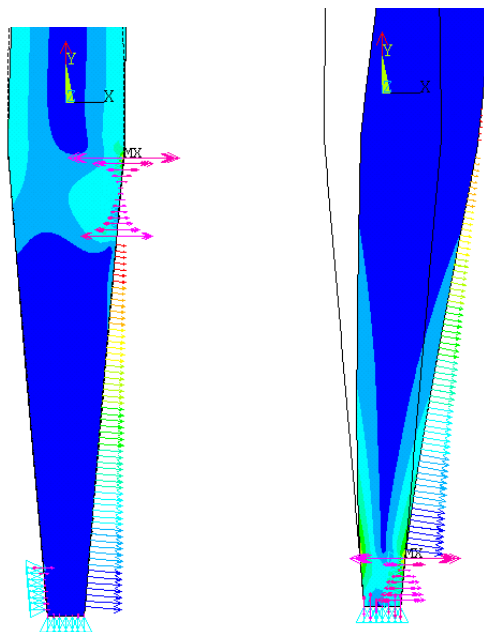

(b) 12.5 m pole.

Figure 7 – Boundary conditions and reactions corresponding to Donut-2 for the two pole sizes. The displacement boundary conditions representing the donut (and the breast block where present) are shown in light blue, the soil pressure is shown in coloured arrows, and the reactions are shown in magenta.

Table 3 – Expected maximum in-service horizontal loads at the base of an electric utility pole. These numbers are based on simplified finite element calculations. The number within brackets is the expected load in the presence of a breast block.

Donut-1 Hole Bearing Load				
Pole size	Expected Max. Load (kN)			Expected Max. Traction (MPa)
9.5 m	260 (0.1)			7.8 (3 KPa)
12.5 m	200 (0.6)			6.1 (18 KPa)
Donut-2 Slot Bearing Load				
Pole size	Expected Max. Load (kN)			Expected Max. Traction (MPa)
	1 pole	2 poles	3 poles	
9.5 m	720 (86)	1440 (172)	2160 (258)	20 (2.4)
12.5 m	695 (120)	1390 (240)	1085 (360)	19.3 (3.4)

Figure 8 shows a plot of the load versus the displacement of the wedge. The hole integrity was maintained for loads greater than the maximum expected load of 15.2 kN for the 12.5 m pole (see Table 2).

5.2.2 Side load/bearing test

For this test, the maximum area over which the load was applied was 0.04 m². The rectangular hole in Donut-1 was an excellent fit onto the test plate that was designed to support an inner face of the rectangular hole. However the curved surface of the donut was uneven and it took a load of approximately 9 kN before the top platen was in total contact with the test piece. From there the load-displacement response was linear until approximately 80 kN. The test was continued until a load of approximately 160 kN when some buckling was observed in the sidewall of the donut between the test rig and upper platen.

Figure 9(a) shows a plot of the load versus the displacement response of Donut-1 during the bearing test. The corresponding traction-displacement curve is shown in Figure 9(b). The confining effect of the soil surrounding the donut is not modelled by this experiment. Therefore, the buckling of the outer curved walls of the donut may not represent the expected in-service behaviour of the block. The maximum expected load on the donut (in the absence of a breast block) is 260 kN (see Table 3) which is significantly higher than what the donut can withstand in bearing. However, if a breast block is used as a leverage point then the expected load is negligible and the donut may be expected to be adequate for service.

5.2.3 Top-load/compression test

The area over which the load was applied in the compression test was 0.14 m². In this simple flatwise compression test it took 90 kN to flatten the upper face of the specimen sufficiently to show a linear load response. From there the load-displacement response stayed largely linear until the test was stopped at approximately 250 kN, the limit of the calibrated load measurement of the test

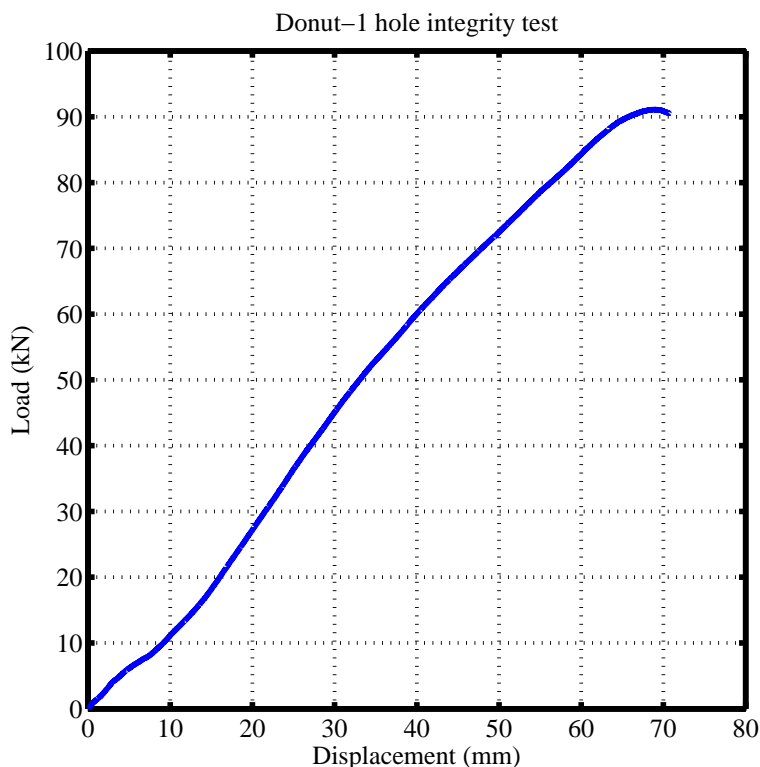

Figure 8 – Load-displacement curve for Donut-1 hole integrity test.

machine.

Figures 10(a) and (b) show plots of the load versus the displacement and traction versus displacement, respectively. The maximum vertical soil pressure on the block is $p = \rho g h = 1500 \times 9.8 \times 2 = 29 \text{ kPa}$. The corresponding load is 4.1 kN. Therefore, the block is more that adequate to resist the weight of the soil above it.

5.3 Donut-2

5.3.1 Slot integrity test

In this case the area of contact of the wedge with the sidewalls of Donut-2 was 0.144 m^2 while the area of contact with the base was 0.0576 m^2 . The wedge block was designed to replicate two poles side by side and was 360 mm wide. The first contact was with the upper lip of Donut-2. The sidewalls were pushed apart by the penetrator until full sidewall contact was achieved at about 2.5 kN. At 2.8 kN the base was engaged with the sidewalls and the load increased rapidly. The test was stopped at 160 kN when a small amount of crushing damage of the base was noted. The base was still bearing load at this point.

Figure 11 shows a plot of the load versus the displacement during the Donut-2 slot integrity test. In this case, the maximum expected vertical load on the base of the slot is approximately 50 kN (see Table 2). The slotted donut will therefore be able to withstand that load quite easily.

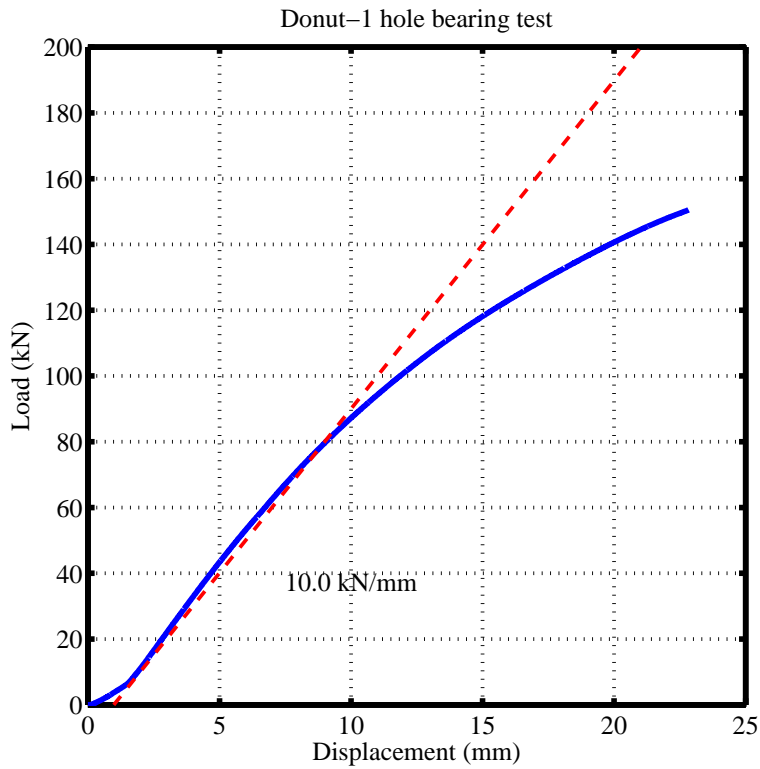

(a) Load vs. displacement.

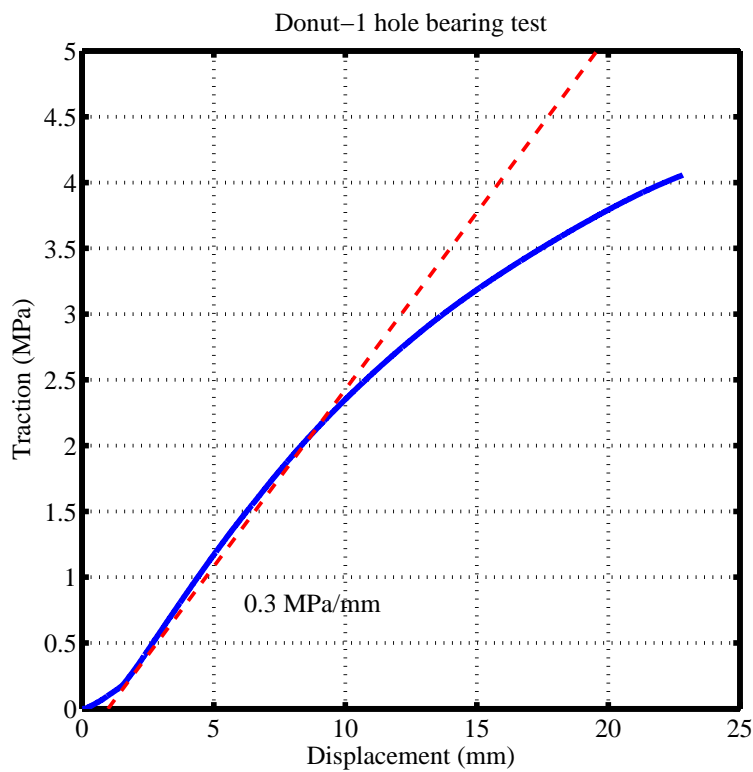

(b) Traction vs. displacement.

Figure 9 – Load and traction as a function of displacement for Donut-1 bearing test.

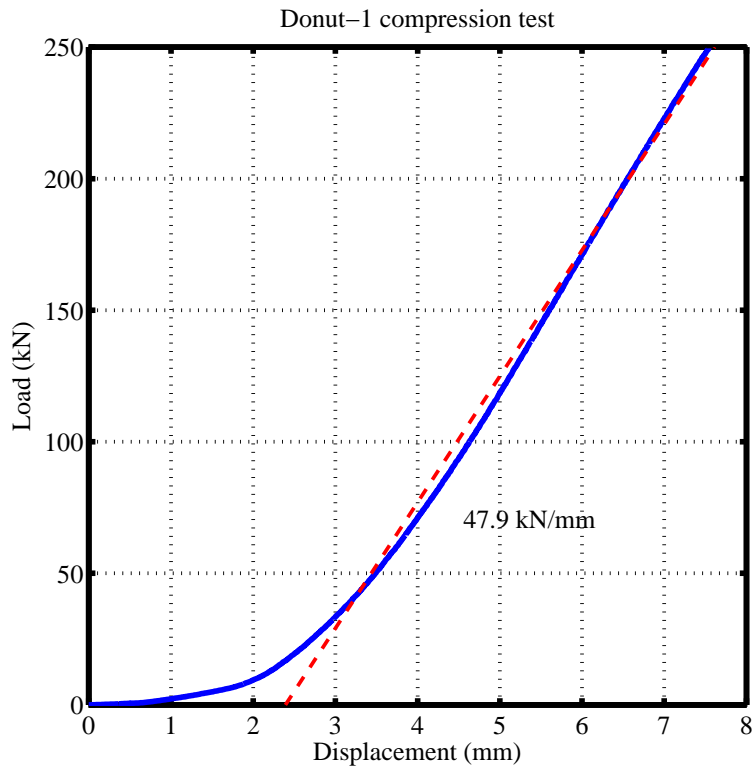

(a) Load vs. displacement.

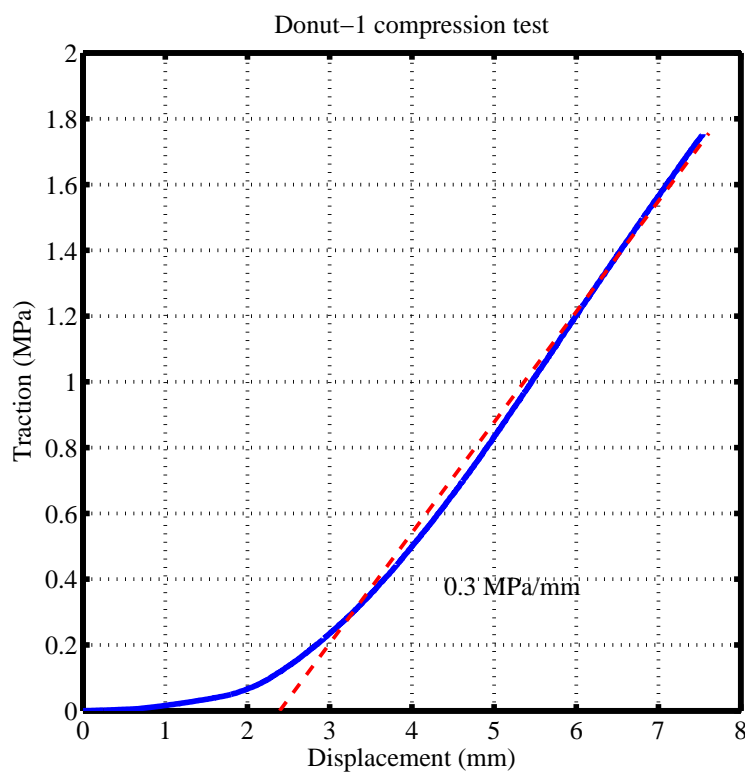

(b) Traction vs. displacement.

Figure 10 – Load and traction as a function of displacement during the compression test on Donut-1.

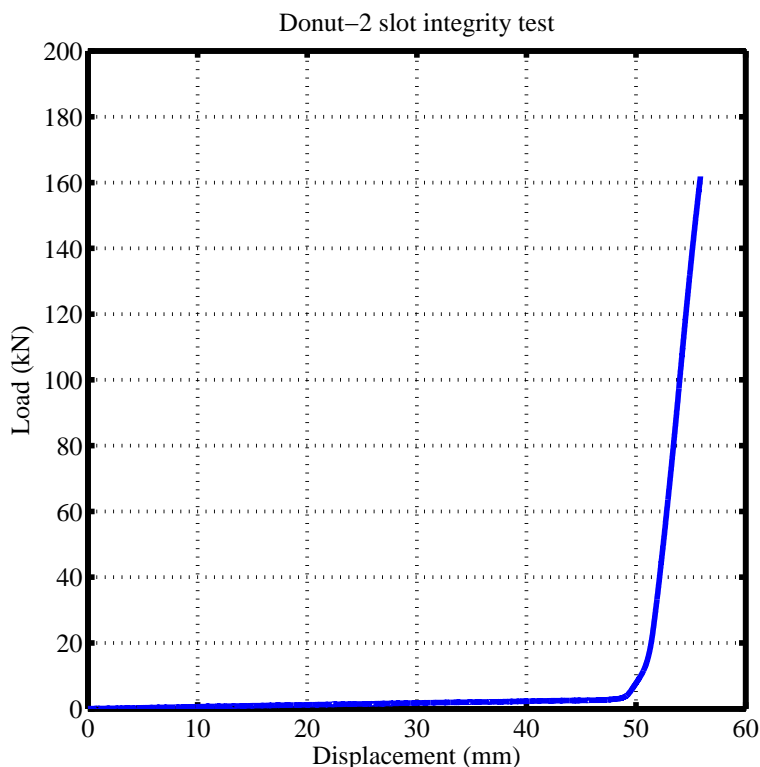

Figure 11 – Load-displacement curve for Donut-2 slot integrity test.

5.3.2 Slot side load/bearing test

The maximum area over which the load was applied for the slot bearing test was 0.072 m². The uneven nature of outside surface of the block led to an initial lack of contact between the specimen surface and top platen. The test rig, however, was an excellent fit to the upper face of the slot. The contact between the test piece and the platen was flattened out by approximately 30 kN. The load-displacement response beyond this point was roughly linear and the linear regime continued up to approximately 150 kN. The test was terminated slightly above 180 kN when some crushing effects were observed on the top surface of the block.

Figure 12(a) shows a plot of the load versus the displacement for the bearing test on Donut-2. The corresponding plot of traction versus displacement is shown in Figure 12(b). The expected loads calculated using the simplified finite element model suggest that large bearing loads (in some regions as large as 700 kN for one pole) may be expected if there is no breast block to act as a leverage point. These loads are significantly higher than those that the block can withstand. However, it should be noted that these loads are based on a model in which the entire surface of the block is assumed to be bonded to the pole. Higher fidelity models are needed to determine the loads more accurately.

In the presence of a breast block, the loads on the slots are reduced significantly. However, even in this case the loads are high enough for the slots to fail due to bearing loads. On the basis of these results, a change in the design of the slotted donut is suggested.

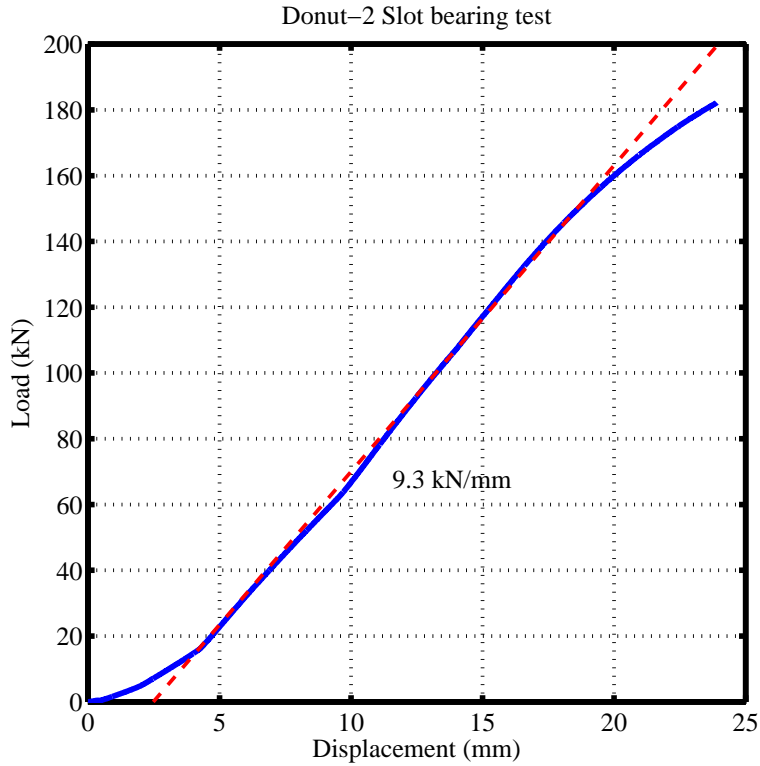

(a) Load vs. displacement.

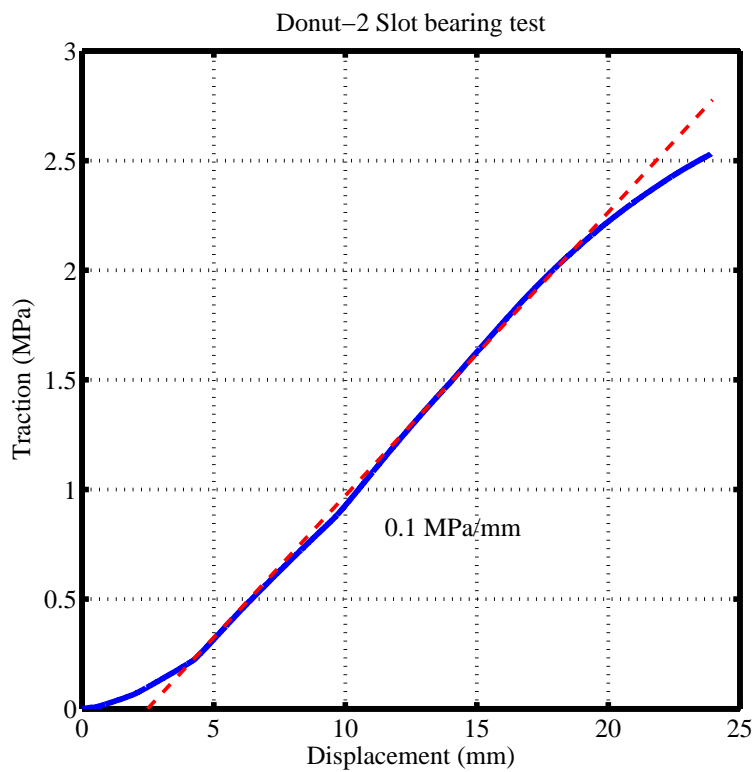

(b) Traction vs. displacement.

Figure 12 – Load and traction as a function of displacement for Donut-2 bearing test.

5.4 Summary

A summary of the mechanical properties deduced from the mechanical tests on the donuts is given in Table 4.

Table 4 – Mechanical properties of Donut-1 and Donut-2.

Property	Donut-1		Donut-2	
Exterior dimensions (cm)	48.8 dia. ×22 high		54×46.5×29.5	
Weight (kg)	14		16	
	Integrity test	Bearing test	Integrity test	Bearing test
Load at yield (kN)	90	100	160	160
Traction at yield (MPa)	-	2.5	-	2.2
Displacement at yield (mm)	66	12	7	20
Effective stiffness (MPa/mm)	-	0.3	-	0.1

6 Conclusions and Recommendations

The major conclusions that may be drawn from the experiments and the finite element analysis are:

1. The strength of the donuts is adequate to support any expected vertical loads.
2. Donut-1 is strong enough to support bearing loads provided a breast block is used to provide a leverage point.
3. Donut-2 is not strong enough in bearing even in the presence of a breast block.

We recommend that

1. Donut-2 be strengthened so that it can withstand larger bearing loads.
2. A detailed simulation of the in-service conditions for Donut-2 be performed so that a better estimate of the peak bearing loads on the donut can be obtained.

Appendix A Photographs of testing rig and samples

Photographs of the testing rigs and the samples are shown in this section. Figure 13 shows photographs of the hole integrity test for Donut-1. Figure 14 shows photographs of the hole bearing test for Donut-1. The compression test setup for Donut-1 is shown in Figure 15.

The slot integrity test for Donut-2 is shown in Figure 16 while the bearing test for Donut-2 is shown in Figure 17.

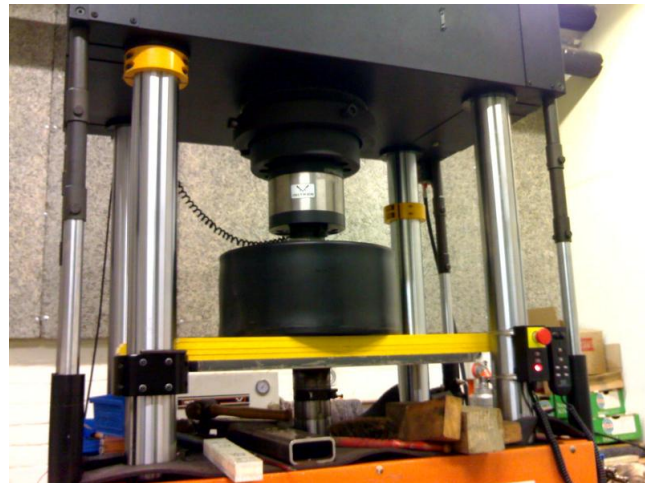
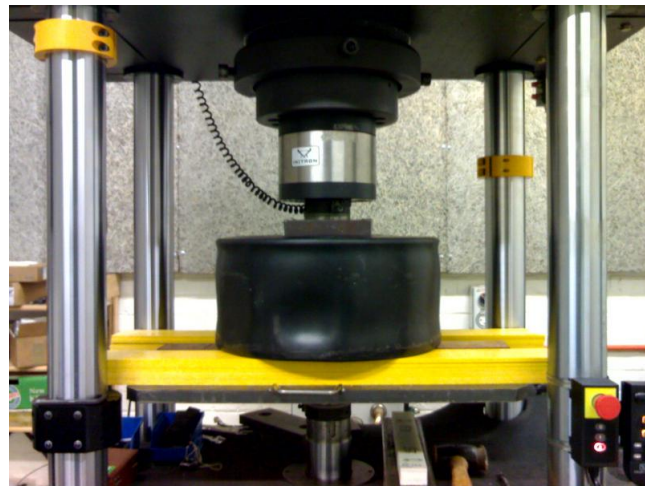

Figure 13 – Donut-1 hole integrity test.



Figure 14 – Donut-1 bearing test.

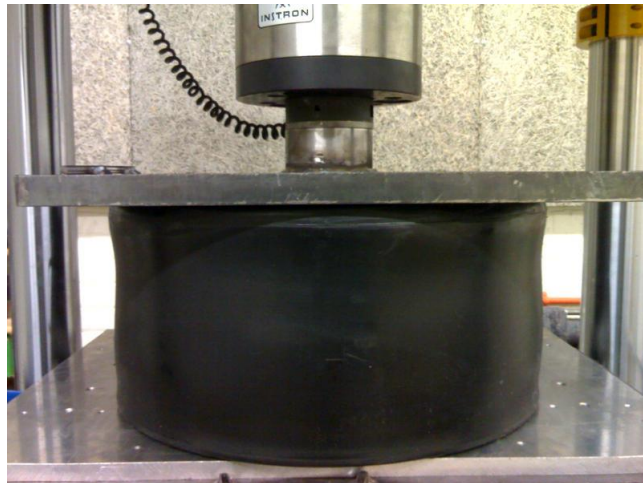
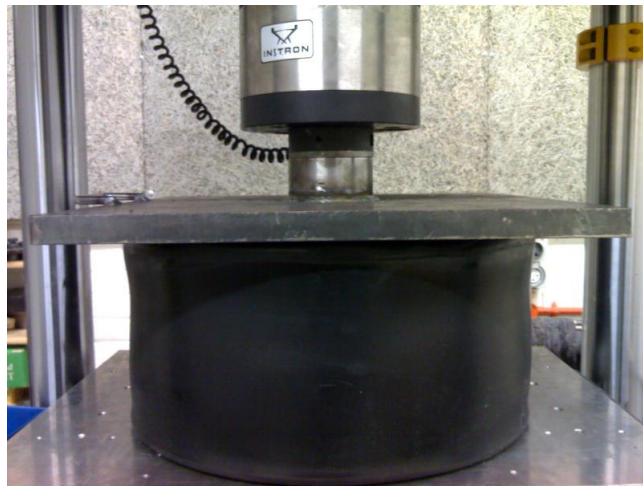

Figure 15 – Donut-1 compression test.

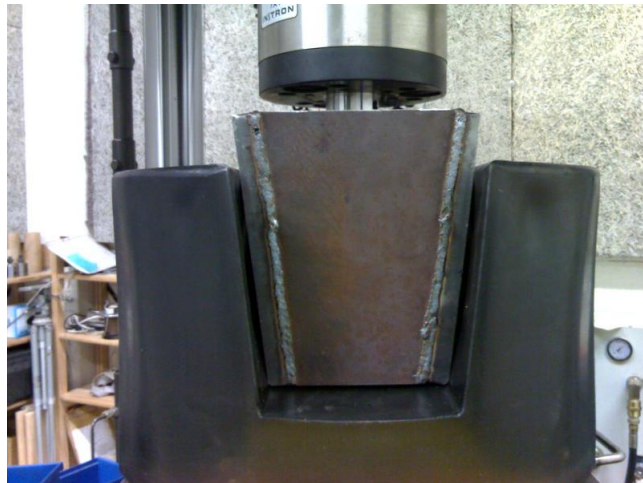
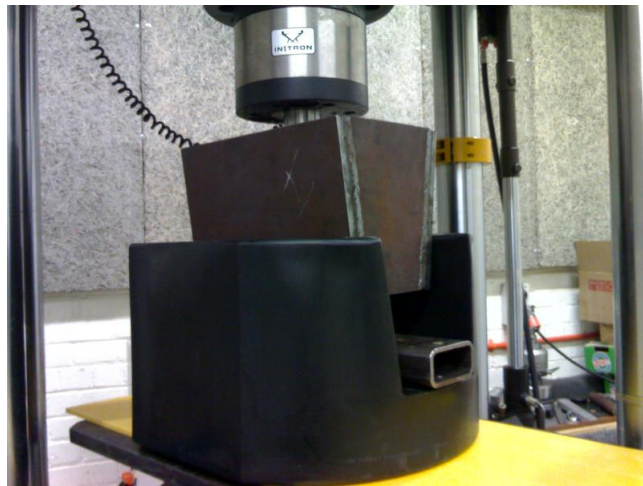

Figure 16 – Donut-2 slot integrity test.

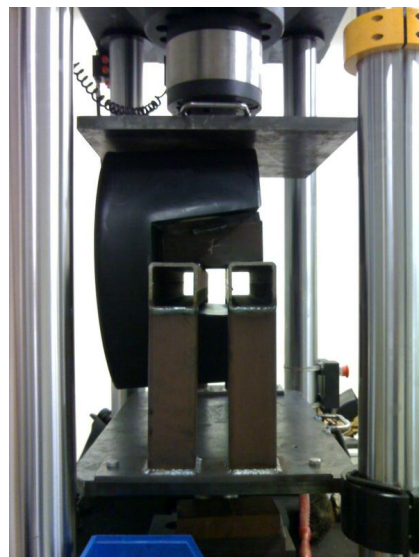
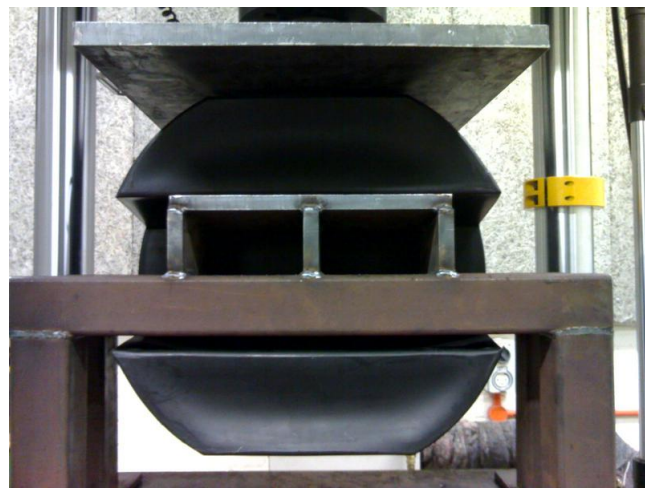
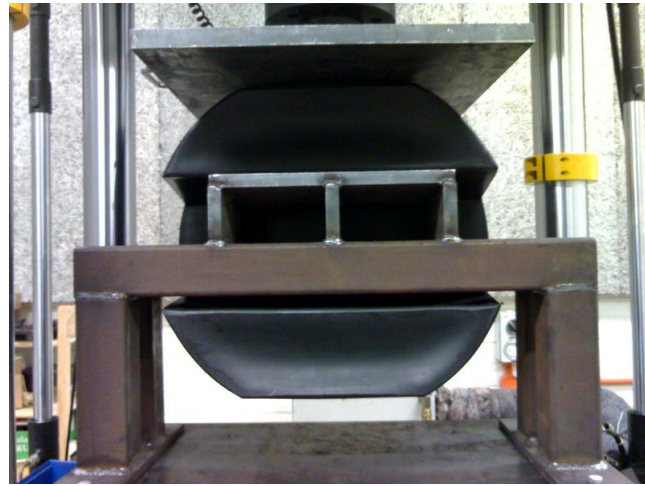

Figure 17 – Donut-2 bearing test.

4th November 2009

TransNet Limited
20 Neilpark Drive
East Tamaki
P O Box 39 383
Howick
Manukau

The Managing Director

Dear Mr Winn

Anchor Block Assessment

Further to your request to determine whether the plastic BB1200 block could be used as an Anchor block, based on the mechanical load test report #36690456.01. The assessment relates to a 10mm thick 350mm x 450mm galvanised steel plate backing onto the block, with a galvanised eyebolt through the block and under tension trying to pull the steel plate through the block.

Our assessment is as follows:

Load on Anchor blocks:

1. The area on the surface of the block over which the steel plate acts is $2 \times (9.5 \times 45 + 5 \times 15) = 1005$ sq. cm.
2. If a load of 200 kN is applied to the centre of the steel plate, the approximate compressive pressure on the anchor block is 2 MPa.
3. Based on IRL Report #36690441/442.01, the creep strain at a compressive stress of 2 MPa is approximately 1% over 20 years. This corresponds to an average creep displacement of 1 mm of the surface of the breast block.
4. The loading plates used in IRL Report #36690456.01 had dimensions of 43 cm x 34.3 cm. The loaded area of block BB 1200 in the tests was 1005 sq. cm. The block BB1200 did not yield when loaded up to 200 kN.
5. The nominal displacement observed in BB 1200 was approximately 10 mm. However, more than 5 mm of this displacement was during initial settling due to the uneven surface of the block. It is expected that the anchor blocks will also deform approximately 5 mm – 15 mm under the action of a 200 kN anchoring load.
6. *Since the anchor block has the same dimensions as BB 1200 and is loaded over an identical area, it is expected that these blocks will also be able to withstand a load of 200 kN.*

Yours sincerely

Biswajit Banerjee
Research Scientist